

# INSTALLATION FOR XTRACTOR X18

**REQUIREMENTS:** Must be used with an equal or greater amount of soffit vent.

**NOTE:** X18 installs on pitches 3/12 to 16/12. If ridge beam is wider than 2", call Customer Service at 800-346-7655.

## Step 1:

Cut a slot in plywood along roof ridge 2" wide (1" on each side). If ridge beam is present, cut slot 1" wide on each side of ridge beam. Allow for a closed area of sheathing 12" at both ends of ridge.

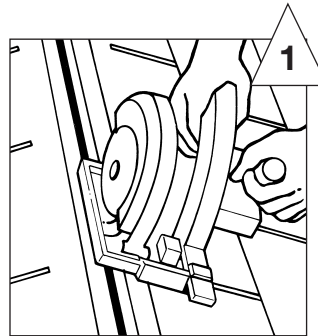

## Step 2:

Place first piece of vent with female end 1" in from gable end and use centering line for proper alignment along peak. Fasten using at least two nails at each end and in middle of section in nail line area (2 1/2" minimum nail length). More may be required on steeper slopes to seat properly. Continue installing additional pieces along ridge sliding female end over male end, aligning using centering line. **NOTE:** In cold weather, allow a 1/8" gap between vent sections for expansion.

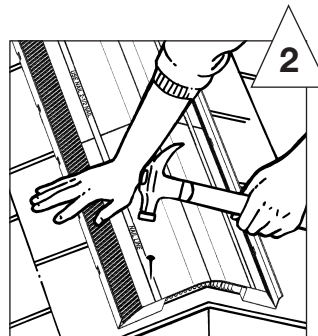

## Step 3:

When reaching the other end, the last vent section may need to be cut to length. End plugs are provided every 12" on underside of the product. Measure amount needed to install to within 1" of gable end. Cut that length in from end of vent section and flip around so that end plug is at gable end. Allow male tab from previous piece to slide under last piece and nail in place.

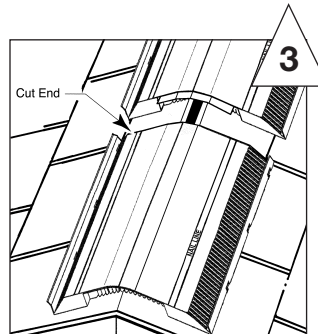

## Step 4:

Place first cap shingle over vent so that it overhangs at least 1" over end of vent section. Install with 2 1/2" nails in nail line area as you work your way down the roof. Cut last cap shingle so that it overhangs vent 1" at other gable end.

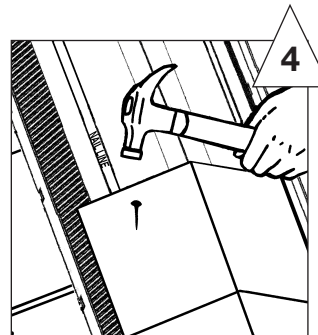

**BENJAMIN  
OBDYKE**

For additional information call:

**800-346-7655**

# INSTALLATION FOR XTRACTOR X18 XTRA

## Requirements:

- Must be used with an equal or greater amount of soffit ventilation
- Installs on pitches 3/12 to 16/12
- Use with standard 12" wide cap shingles
- Use 2-1/2" minimum nails to assure penetration of 3/4" into sheathing or completely through the sheathing

## Step 1:

Cut a slot in plywood along roof ridge 2" wide (1" on each side). If ridge beam is present, cut slot 1" wide on each side of ridge beam. Allow for a closed area of sheathing 12" at both ends of ridge.

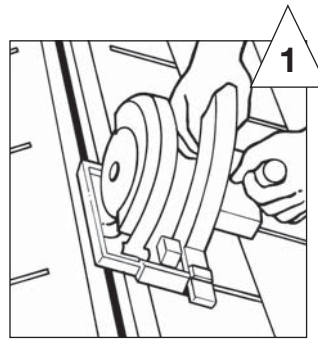

## Step 2:

Place first piece of vent with female end 1" in from gable end and use centering line for proper alignment along peak. Fasten using at least two nails at each end and in middle of section in nail line area (2-1/2" minimum nail length). More may be required on steeper slopes to seat properly. Continue installing additional pieces along ridge sliding female end over male end, aligning using centering line.

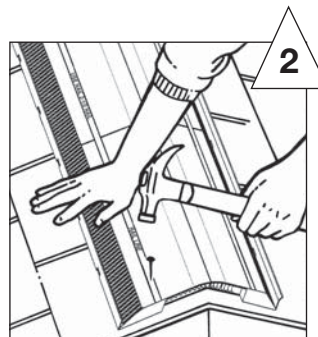

NOTE: In cold weather, allow a 1/8" gap between vent sections for expansion.

## Step 3:

When reaching the other end, the last vent section may need to be cut to length. End plugs are provided every 12" on underside of the product. Measure amount needed to install to within 1" of the gable end. Cut that length in from end of vent section and flip around so that end plug is at gable end. Allow male tab from previous piece to slide under last piece and nail in place.

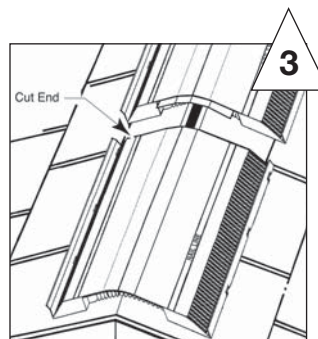

## Step 4:

Place first cap shingle over vent so that it overhangs at least 1" over end of vent section. Install with 2-1/2" nails in nail line area as you work your way down the roof. Cut last cap shingle so that it overhangs vent 1" at other gable end.

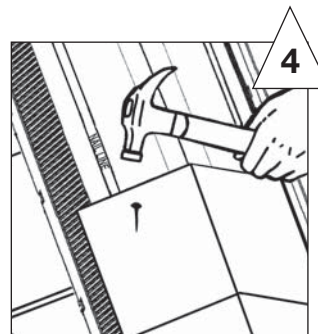

**BENJAMIN  
OBDYKE**

For additional information call:  
**800-346-7655**

# INSTALLATION FOR XTRACTOR VENT XLP

**REQUIREMENTS:** Must be used with an equal or greater amount of soffit vent.

**NOTE:** Compressor pressure should be between 80 psi and 100 psi, depending on conditions. XLP installs on pitches 3/12 to 16/12. If ridge beam is wider than 2", call Customer Service at 800-346-7655.

## Step 1:

Cut a slot in plywood along roof ridge 1 1/2" wide (3/4" on each side). If ridge beam is present, cut slot 3/4" wide on each side of ridge beam. Allow for a closed area of sheathing 12" at both ends of ridge.

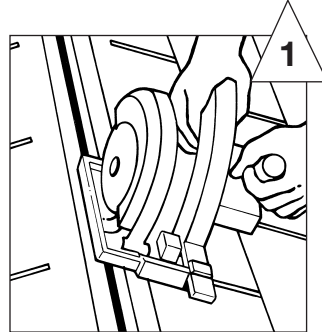

## Step 2:

Place first piece of vent with female end 1" in from gable end and use centering line for proper alignment along peak. Fasten using at least two nails at each end and in middle of section in nail line area (1 3/4" minimum nail length). More may be required on steeper slopes to seat properly. Continue installing additional pieces along ridge sliding female end over male end, aligning using centering line. **NOTE:** In cold weather, allow a 1/8" gap between vent sections for expansion.

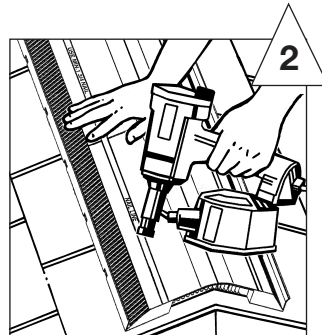

## Step 3:

When reaching the other end, the last vent section may need to be cut to length. End plugs are provided every 12" on underside of the product. Measure amount needed to install to within 1" of gable end. Cut that length in from end of vent section and flip around so that end plug is at gable end. Allow male tab from previous piece to slide under last piece and nail in place.

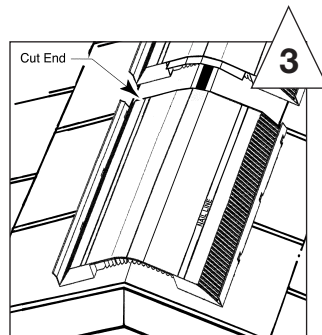

## Step 4:

Place first cap shingle over vent so that it overhangs at least 1" over end of vent section. Install with 1 3/4" nails in nail line area as you work your way down the roof. Cut last cap shingle so that it overhangs vent 1" at other gable end.

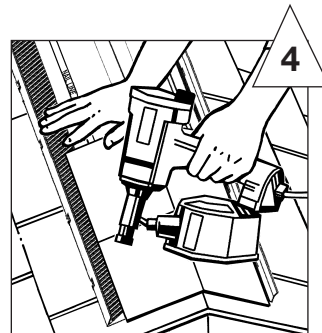

**BENJAMIN  
OBDYKE**

For additional information call:

**800-346-7655**

**INSTALLATION INSTRUCTIONS\***

**Requirements**

- Compressor pressure should be set between 90–100 psi
- Must be used with an equal or greater amount of soffit vent
- Installs on pitches from 3/12 to 16/12
- Use with standard 12" wide cap shingles
- Use 1 3/4" nails provided to assure penetration into the sheathing 3/4" or completely through the sheathing

**STEP 1**

Cut a slot in plywood along the roof ridge 1 1/2" wide (3/4" on each side). If ridge beam is present, cut slot 3/4" wide on each side of ridge beam. Allow for a closed area of sheathing 12" at both ends of ridge.

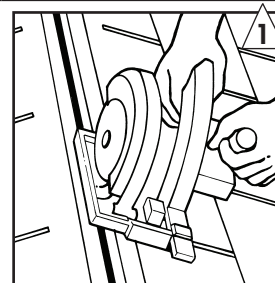

**STEP 2**

Place beginning female end of vent 1" in from gable end and use centering line for proper alignment along peak. Fasten using at least two nails at each end and in middle of roll in nail line area (1 3/4" minimum nail length) spacing approximately every 12 inches. More nails may be required on steeper slopes to seat properly. Continue installing additional rolls as needed along ridge sliding female end over male end, aligning using centering line. When reaching the other end, cut vent roll to 1" from the gable end and nail in place. End plugs are provided every 6" on the underside of the product.

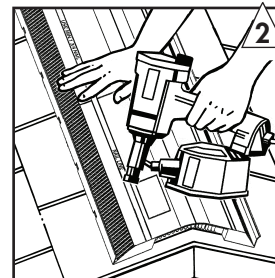

**STEP 3**

Place first cap shingle over vent so that it overhangs at least 1" over end of vent roll. Install with 1 3/4" nails provided in nail line area as you work your way down the roof. Cut last cap shingle so that it overhangs vent 1" at other gable end.

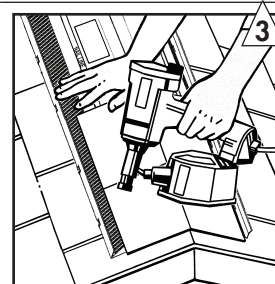

\* Please consult Xtractor Vent Application & Architectural Drawings brochure for proper installation with hip & ridge applications.

**SPECIFICATIONS**

Length	25'
Height	5/8"
Width	14"
NFA	12.75 sq. in./ft.
Quantity	1 roll per box
Warranty	40-year limited

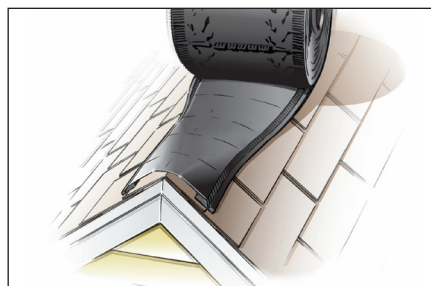

No more sections to piece together—the rolled design of XLP Turbo allows for quick and easy installation.